

AZAR 102

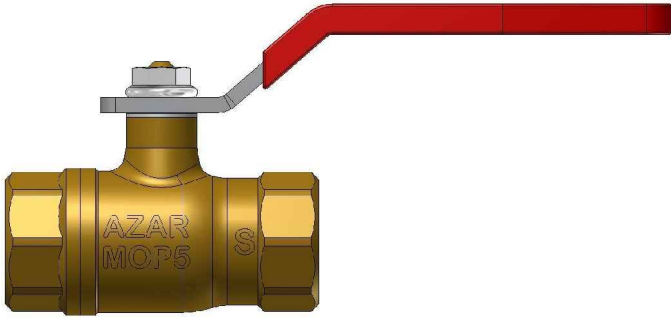

AZAR 102A

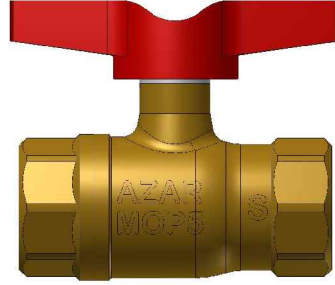

AZAR 102B

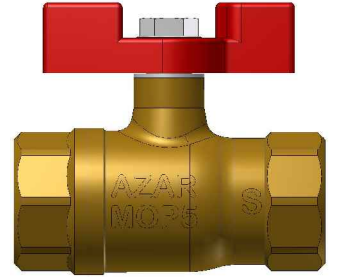

AZAR 102C

سبک وزن
Light Weight

کد محصول Code No.	سایز Size	Z (mm)	Y (mm)	X (mm)	سوراخ توپی Bore Size (mm)	وزن Weight (gr)	DN	تعداد در کارتن Q. In Box
AZAR 102A	NPT 1/2"	62	47	101	ø10	232	15	80(8x10)
	NPT 3/4"	71	51	101	ø15	338	20	60(6x10)
	NPT 1"	83	55	116	ø20	539	25	40(4x10)
AZAR 102B	NPT 3/4"	71	45	65	ø15	332	20	60(6x10)
AZAR 102C	NPT 1/2"	62	40	50	ø10	193	15	80(8x10)

Ambient Temperature : (-29°C ... +66°C) – For Water: (+5°C ... +80°C)
Work Pressure: Shell 400psi. W.O.G(Non-Shock)
Seat 100psi.

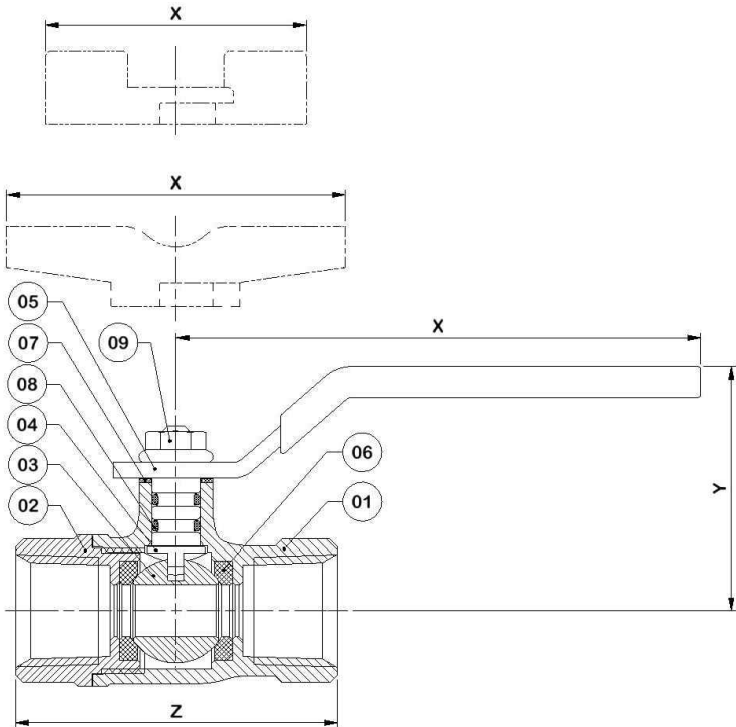

NO.	Part Name	نام قطعه	جنس Material
01	Body	بدنه	Brass
02	Body Cap	درپوش بدنه	Brass
03	Ball	توپی	Brass (Nickel-Chrome Plated)
04	Stem	ساقه	Brass
05	Handle	دسته	AZAR 102A : Steel (Zinc Plated) – Cover (PVCE) AZAR 102B (3/4") : Zamac (Painted) AZAR 102C (1/2") : AL. (Painted)
06	Seat	تفلون نشیمنگاه توپی	PTFE
07	Washer	واشر زیر دسته	PE
08	O-ring	اورینگ	NBR
09	Hex Nut-DIN 6923	مهرد شش گوش لبه دار	Steel (Zinc Plated)

Test Pressure: Shell 600psi.(Hydrostatic)
Seat 100psi.(Air) 25°C±5